

JD

PI

JD

JD

72.00

71.00

9.40

72.00

71.00

70.00

9.40

69.00

68.00

9.40

68.00

68.00

69.00

86.00

8.2

SUELO

REF. CAT.: 4836803BC5943N0001XW

POR

+TZA

POR

P

DI

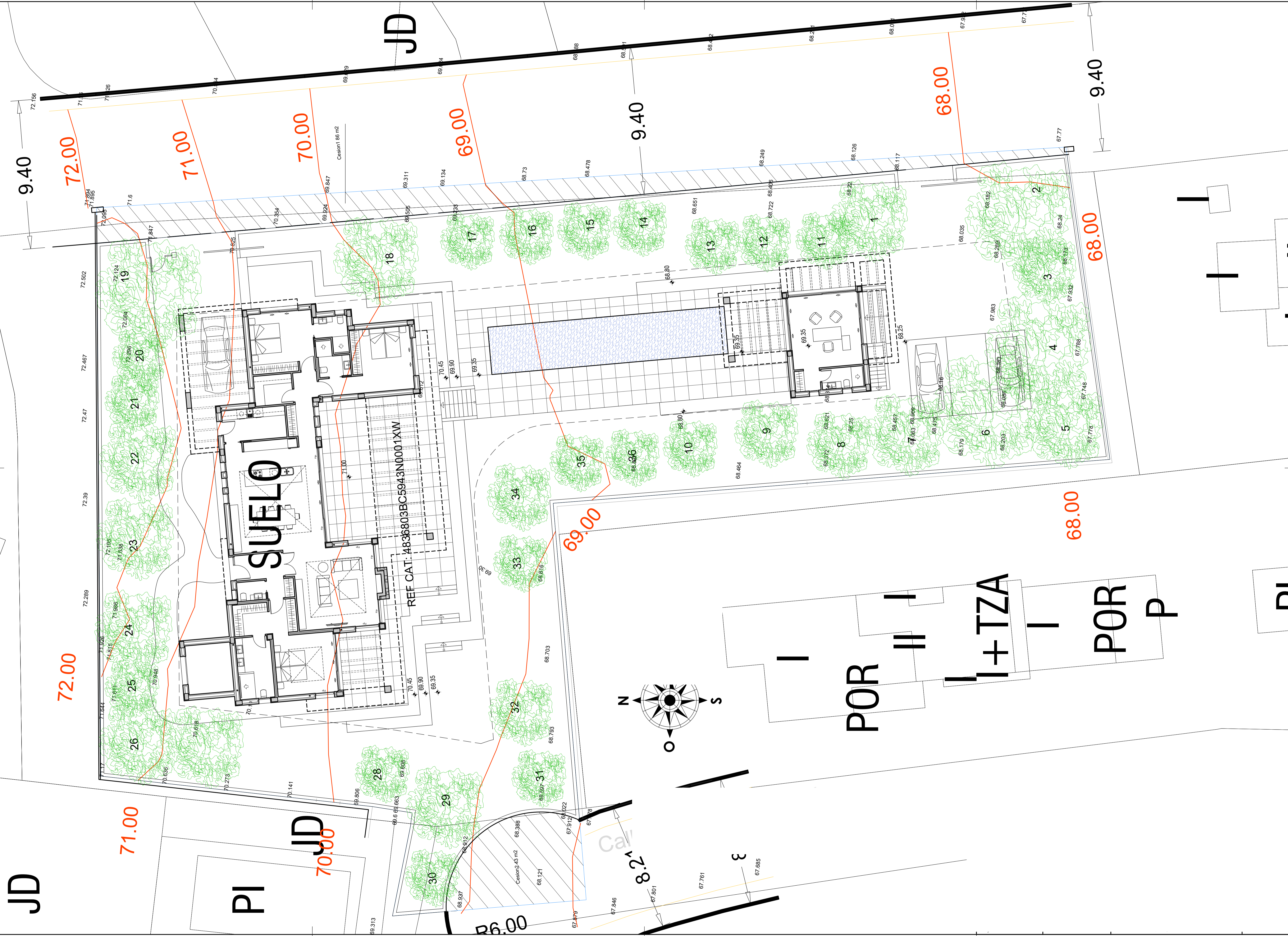
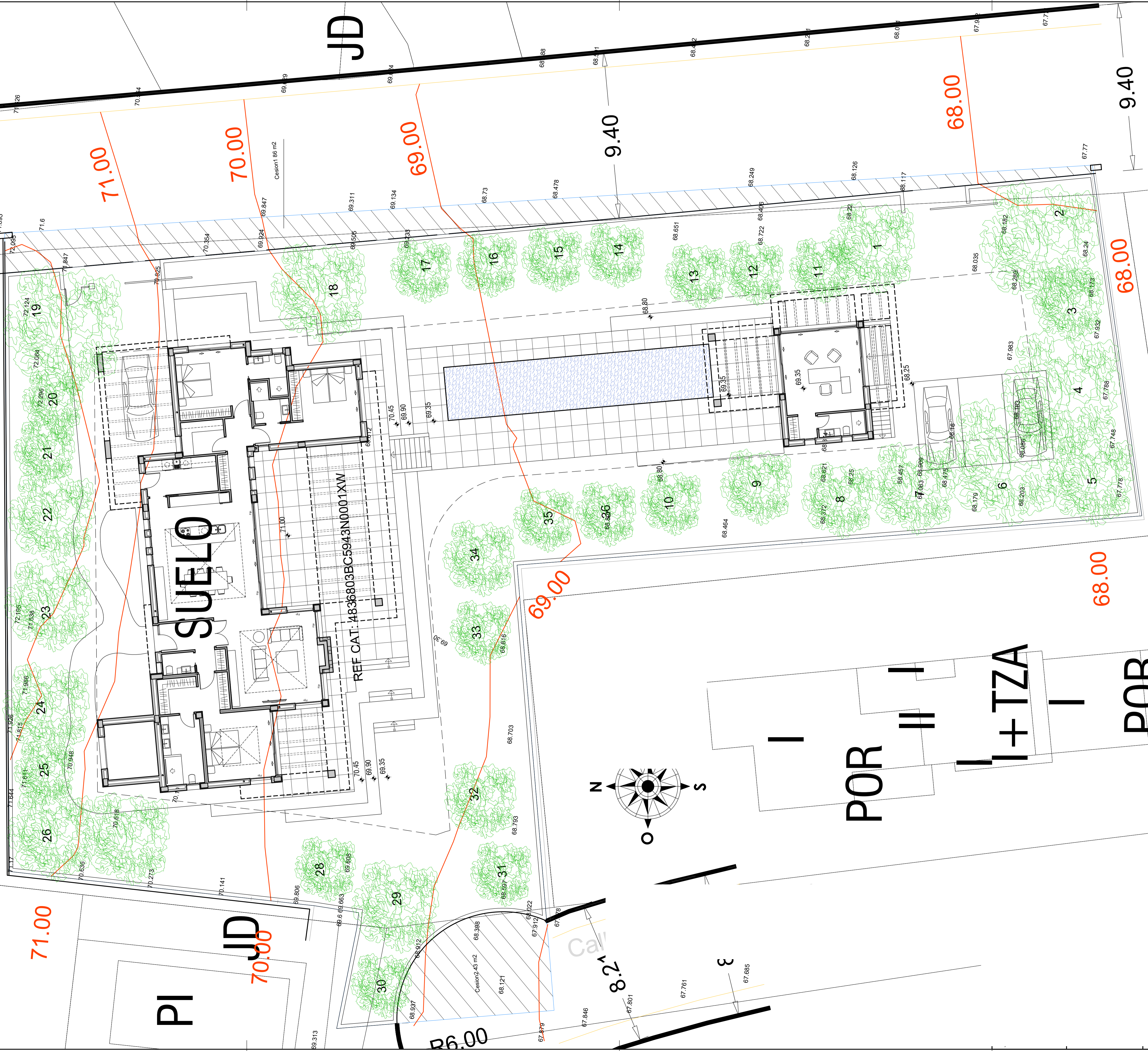
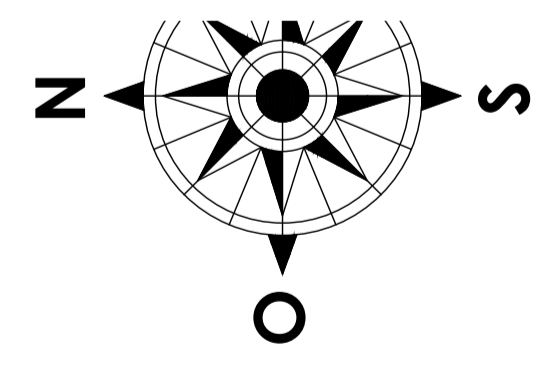

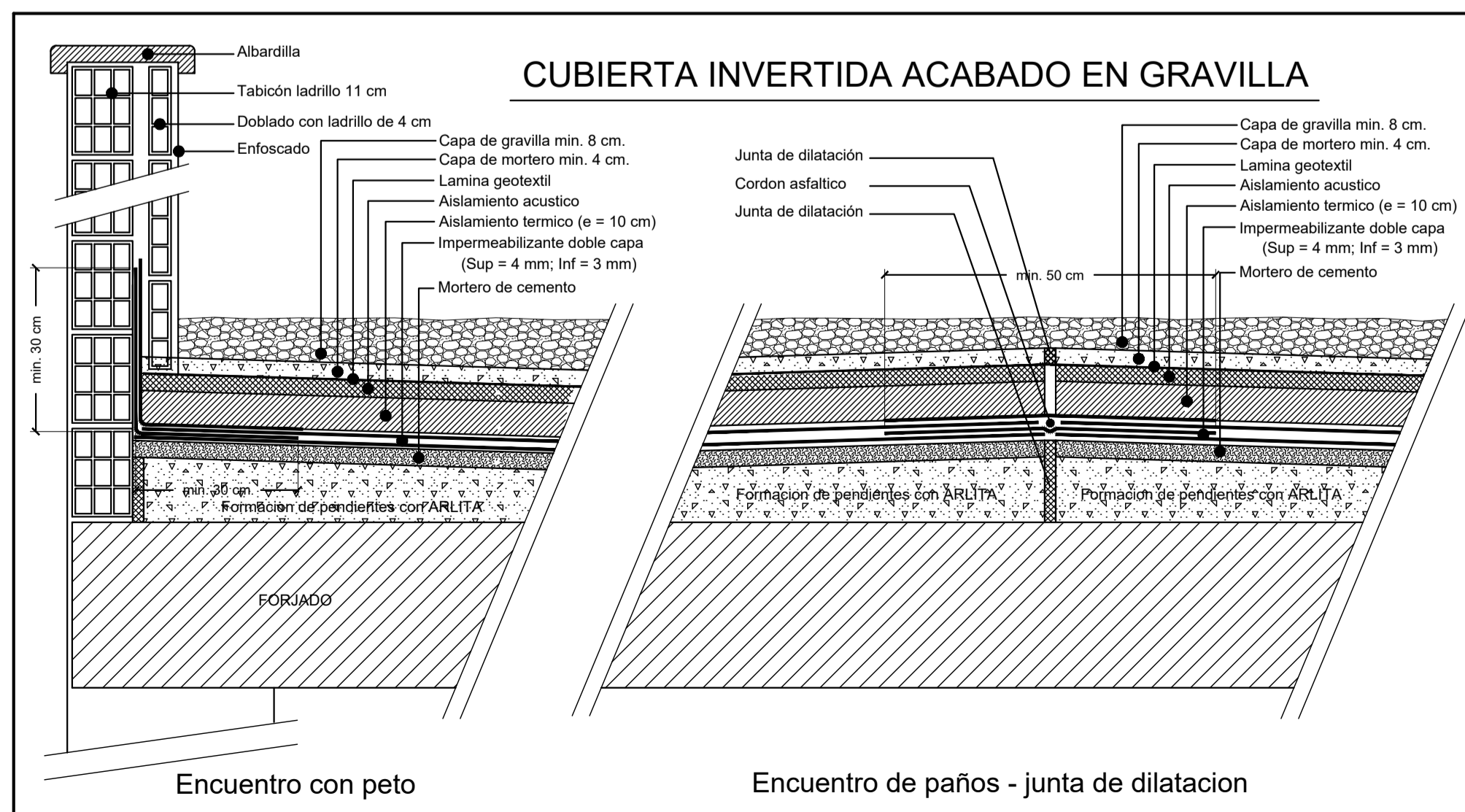
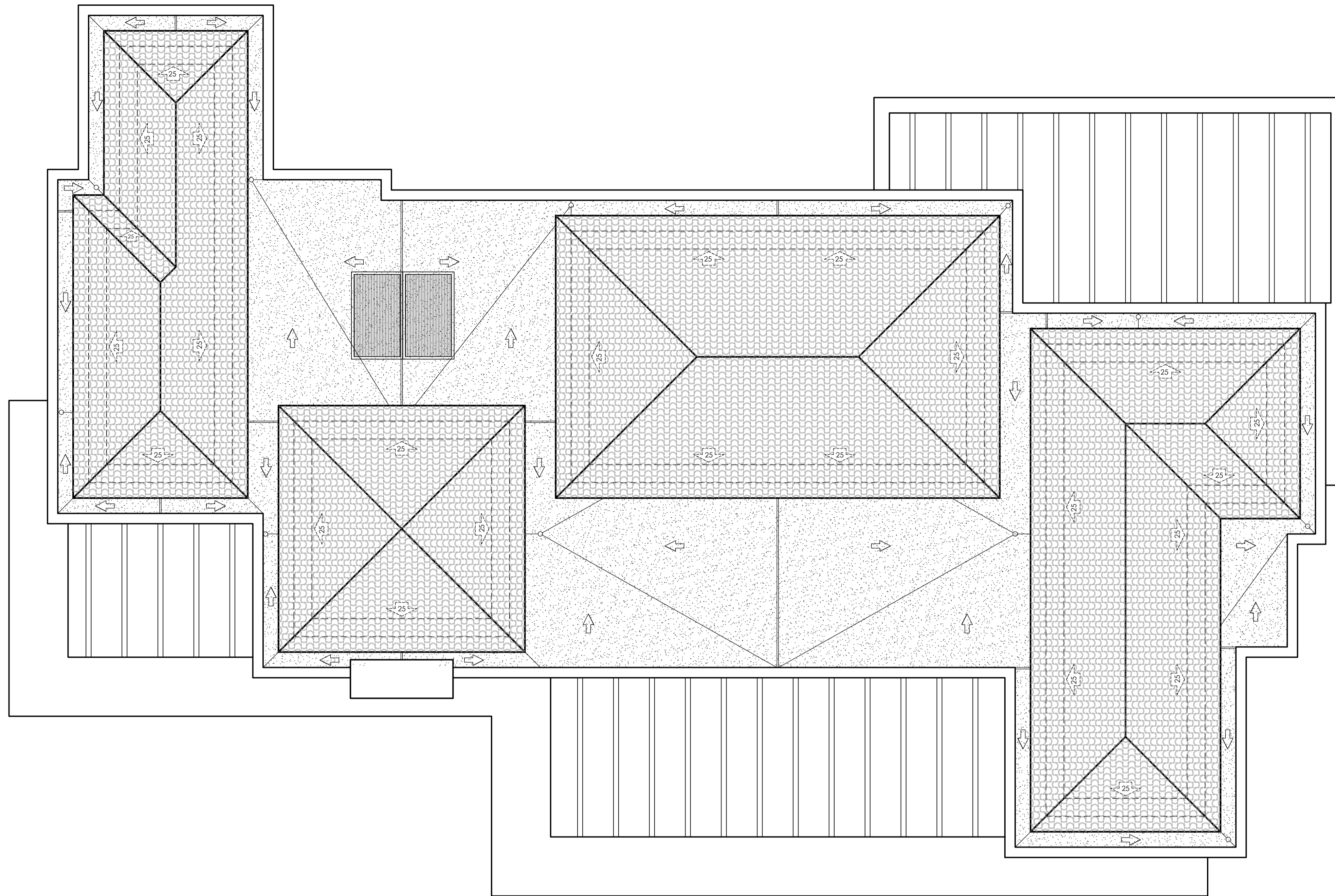

QTT-11 FALDON DE TEJA CURVA-S-Tipo

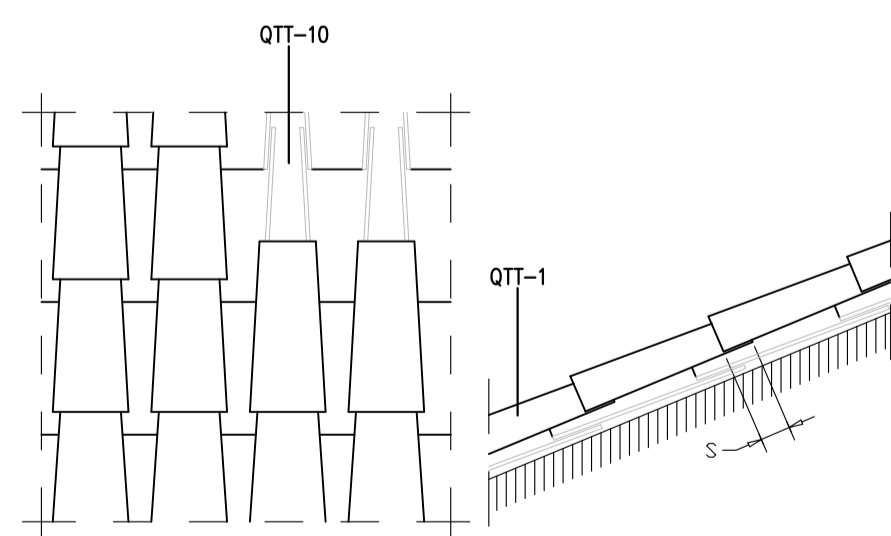

QTT-14 ALERO TEJA CURVA-Tipo

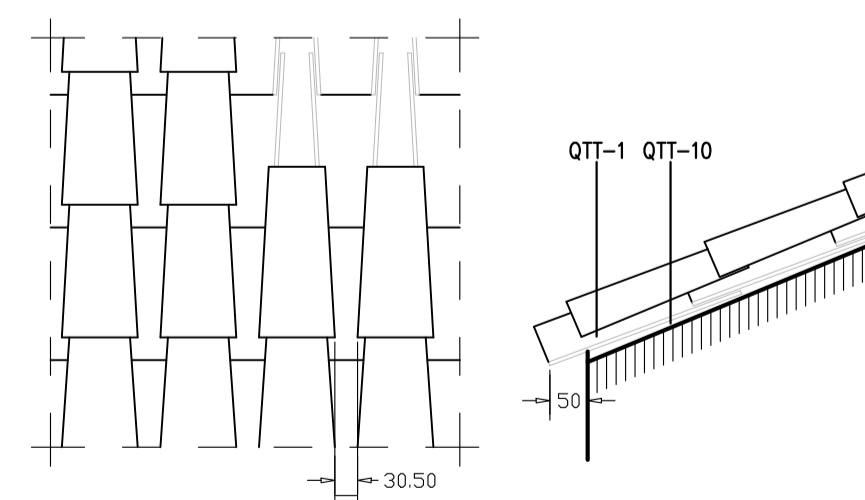

QTT-19 CUMBRERA DE TEJA CURVA-Tipo

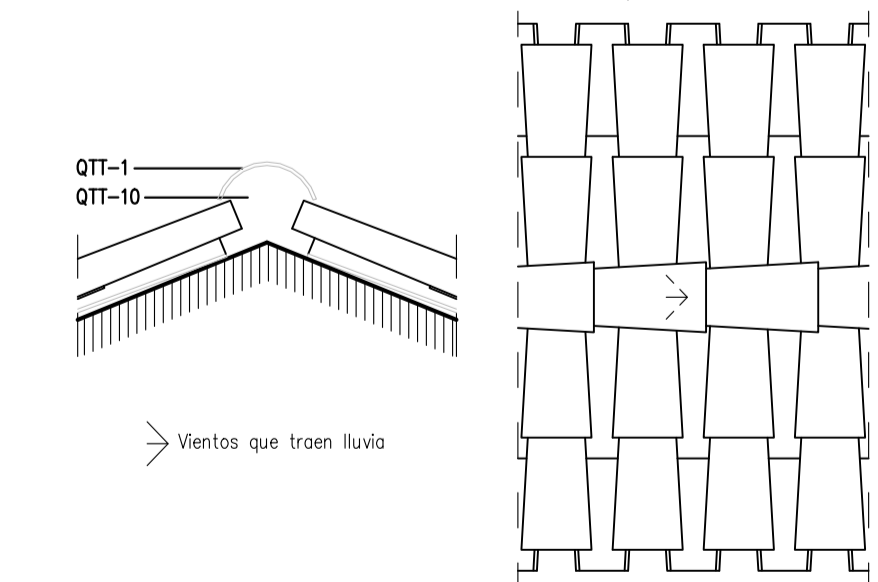

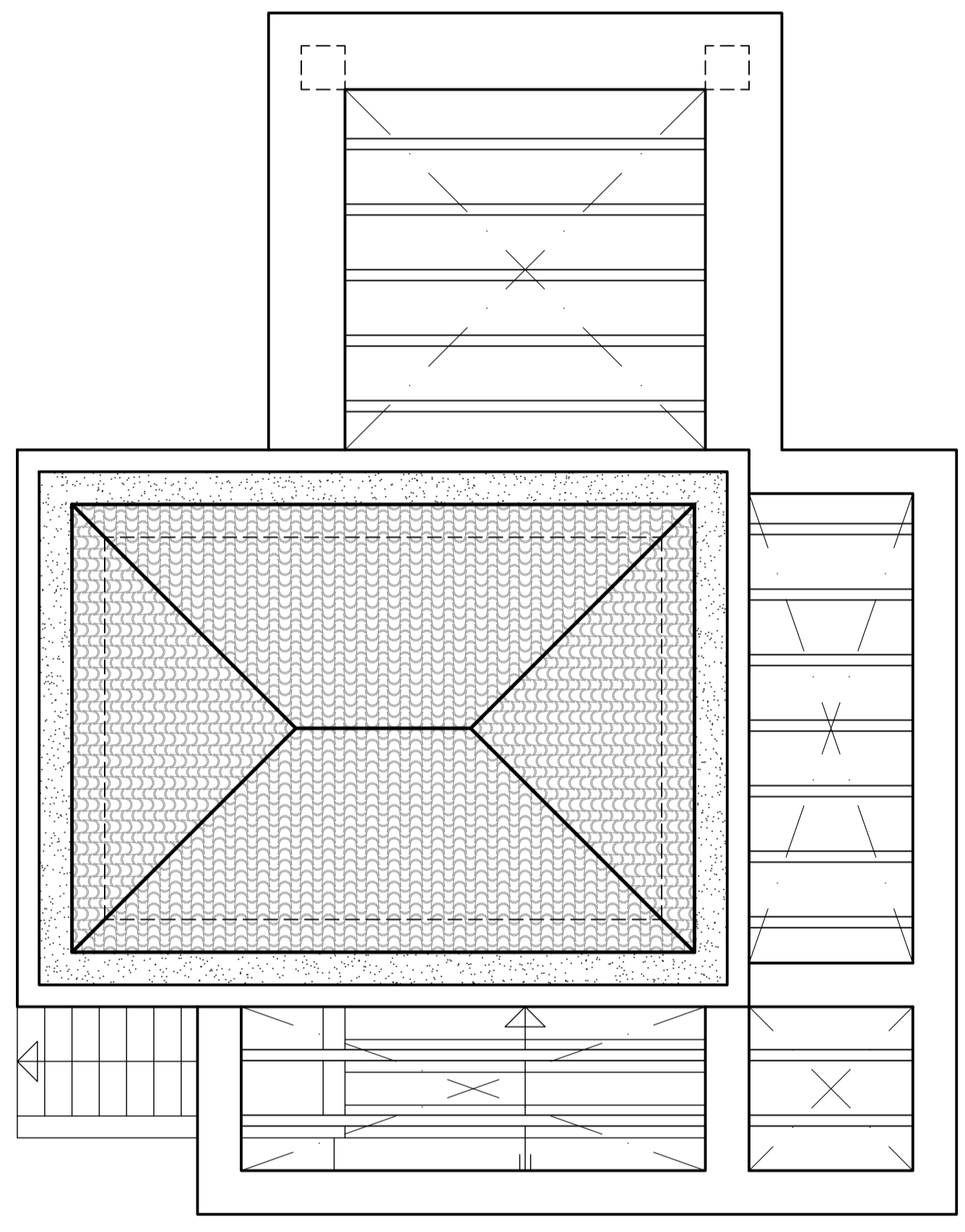
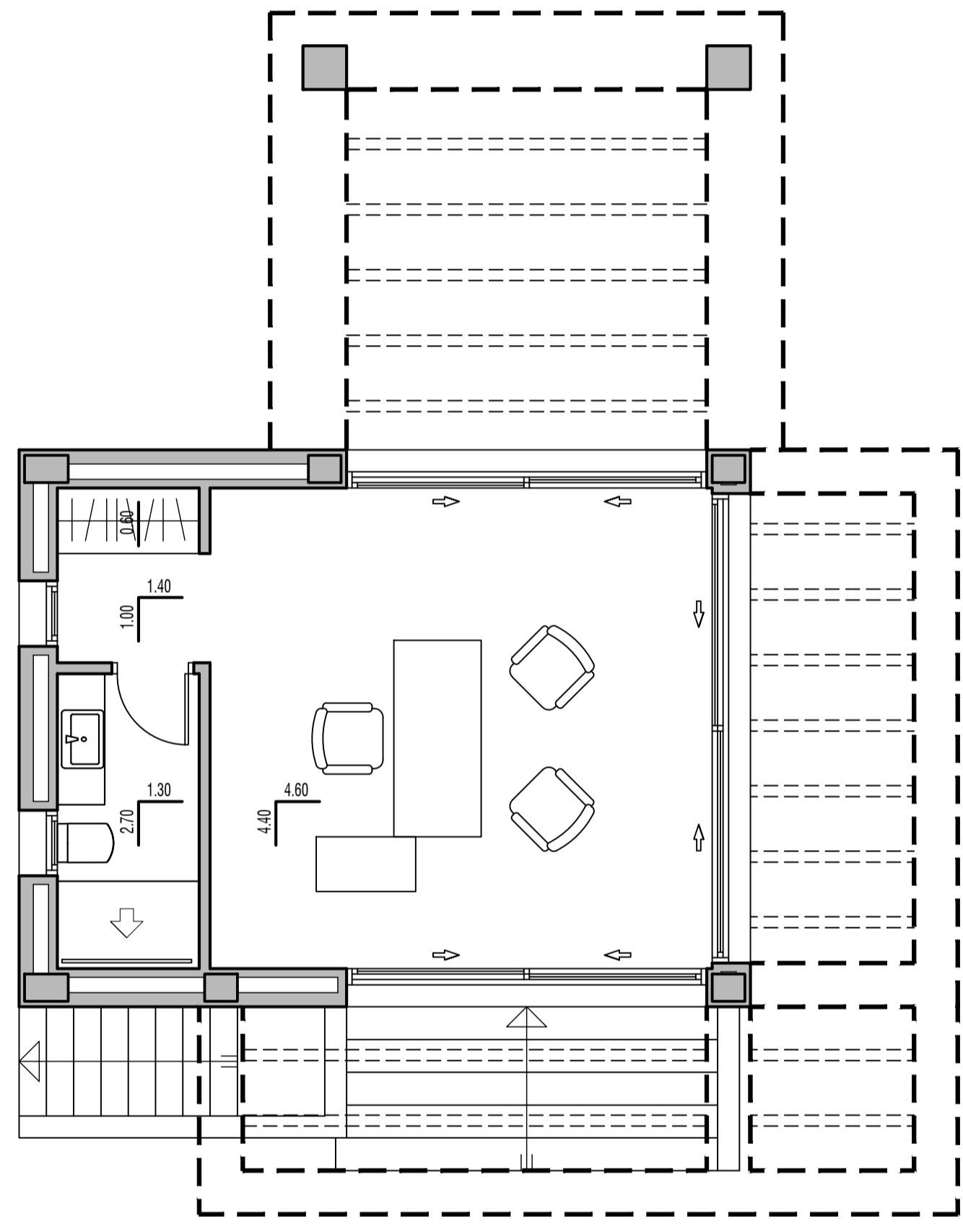
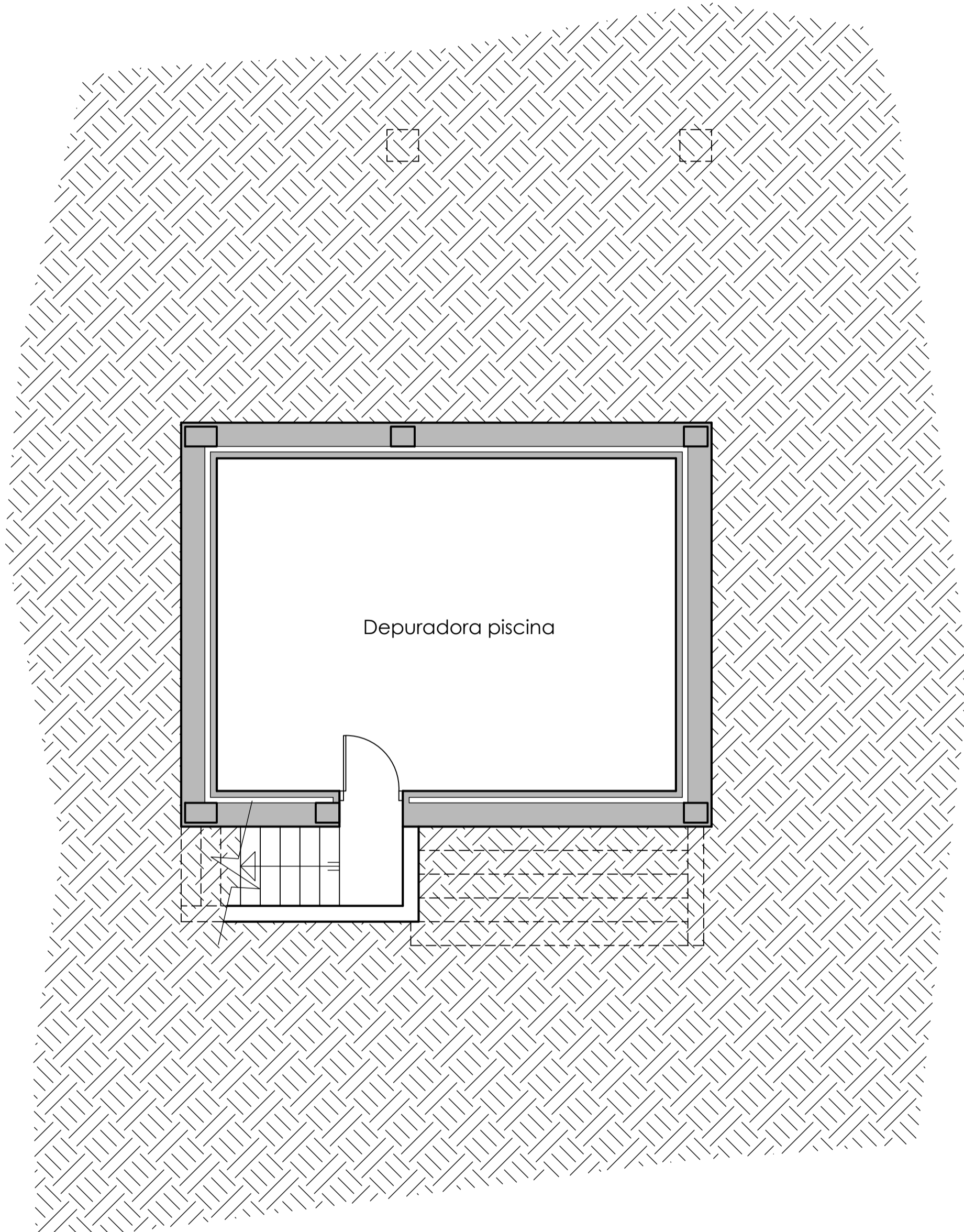

SUPERFICIES CONSTRUIDAS		
	Construida	Computable
Depuradora.....	34.15 m ²	0.00 m ²
Estudio	34.15 m ²	34.15 m ²
Pergola	41.70 m ²	0.00 m ²
Escaleras	9.00 m ²	0.00 m ²
TOTAL	110.00 m ²	34.15 m ²